

GE Energy

even in the middle of nowhere

cogeneration with
Jenbacher gas engines



GE imagination at work

cogeneration of heat and power

Cogeneration systems – also called combined heat and power or CHP systems – generate both heat and power. Jenbacher CHP systems economically utilize the waste heat incurred during engine operation to generate overall plant efficiencies of more than 90%. This efficient form of energy conversion achieves primary energy savings of roughly 40% by using a gas engine cogeneration system instead of separate power and heat generation equipment. Transportation and distribution losses are also reduced or eliminated as the decentralized energy supply is set up where it is needed.

the Jenbacher concept

The basic structure of a Jenbacher CHP system consists of an engine/generator unit and heat exchangers for the utilization of waste heat. The incorporation of a wide range of heat sources – from engine cooling water, oil and air/fuel gas mixture to exhaust gas – is configured to maximize the benefit to each individual customer.

Cogeneration systems can be supplemented with a boiler system for bridging peak heat demand periods. An additional increase in the operating time and efficiency of the system is made possible by the connection of a heat storage medium. Power plant electrical switch and control systems distribute the electricity and manage the engine, while hydraulic equipment ensures the heat distribution.

The generated power is utilized by the individual facilities (e.g., hospitals) or fed into the public power grid. The thermal energy can be used for both generating heating water and steam production as well as for various types of process heat. Gas engine cogeneration systems are also used for CO₂ fertilization in greenhouses and trigeneration systems (combined generation of heat, cooling and power).

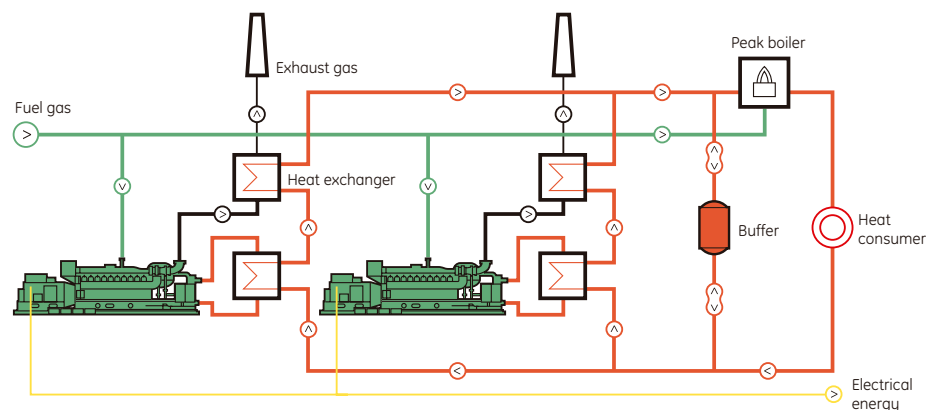

advantages of Jenbacher cogeneration systems

- High electrical efficiencies of up to 43%
- Overall efficiencies (electrical and thermal) of over 90%
- Wide range of power and heat outputs
- Minimum emissions through the patented LEANOX® lean mixture combustion
- Compact design requires a comparatively small footprint
- Specially designed engines for utilization of alternative energy sources (e.g., biogas, landfill gas, coal mine gas, or coke gas)
- Maximum operational safety and availability
- Low investment costs



key figures

A cogeneration plant with 1,000 kW_{el} and 1,250 kW_{th} can meet the following heat demands:

- Short-distance heating network approximately 12,500 m² of residential area
- Hospital approximately 150 beds
- Building supply approximately 10,000 m² of useful area (floor space)

our competence

The first Jenbacher gas engine was built in 1957. Currently more than 3,270 Jenbacher cogeneration plants with a total electrical output of over 3,500 MW are in operation worldwide. Increases in energy costs, environmental concerns and energy demands will continue to promote the future growth of CHP systems. Jenbacher's innovative cogeneration systems will continue to lead the way.



GE Energy's gas engine business is one of the world's leading manufacturers of gas-fueled reciprocating engines, packaged generator sets and cogeneration units for power generation. It is one of the only companies in the world focusing exclusively on gas engine technology.

Jenbacher engines range in power from 0.25 to 3 MW and run on either natural gas or a variety of other gases (e.g., biogas, landfill gas, coal mine gas, sewage gas, combustible industrial waste gases).

A broad range of commercial, industrial, and municipal customers use Jenbacher products for on-site generation of power, heat, and cooling. Patented combustion systems, engine controls, and monitoring enable its power generation plants to meet the strictest international emission standards, while offering high levels of efficiency, durability, and reliability.

GE Energy's Jenbacher product team has its headquarters, production facilities, and 1,000 of its more than 1,250 worldwide employees in Jenbach, Austria.



for more information on Jenbacher products

Austria (Headquarters)

Achenseestraße 1-3
A-6200 Jenbach
T +43 5244 600-0
F +43 5244 600-527
E info@gejenbacher.com
www.gejenbacher.com

Denmark

Industrivej 19
DK-8881 Thorsø
T +45 86966788
F +45 86967072

Germany

Amselstraße 28
D-68307 Mannheim
T +49 621 77094-0
F +49 621 77094-70

Hong Kong

15 Floor, The Lee Gardens
33 Hysan Avenue Causeway Bay
T +852 2100 6976
F +852 2100 6630

Italy

Via Crocioni, 46/H, Casella Postale n. 41 Aperta
I-37012 Bussolengo (VR)
T +39 045 6760211
F +39 045 6766322

Spain and Portugal

Avda. del Camino de lo Cortao, 34 - Nave 8
E-28700 San Sebastián de los Reyes (Madrid)
T +34 916586800
F +34 916522616

The Netherlands

Stationspark 750
NL-3364 DA Sliedrecht
T +31 184 495222
F +31 184 415440

United Arab Emirates

Dubai Airport Free Zone, W 1, Suite 220
PO Box 54338, Dubai
T +971 4 2996678
F +971 4 2996679

USA

15855 Jacinto Port Blvd
Houston, TX 77015
T +1 281 8642765
F +1 281 8642506

