

GE Energy

# keep cool

trigeneration with  
Jenbacher gas engines



GE imagination at work

# trigeneration of heat, cooling and power

Absorption chillers provide an economic and environmental alternative to conventional refrigeration. Combining high efficiency, low emission power generation equipment with absorption chillers allows for maximum total fuel efficiency, elimination of HCFC/CFC refrigerants and reduced overall air emissions.

## possibilities for refrigeration

Absorption chillers:

- Operation with hot water
- Operation with steam
- Direct heat through combustion

Compression-type refrigeration machines:

- Direct drive power
- Electrical drive power

## absorption chillers

Absorption chillers produce chilled water by heating two substances (e.g., water and lithium bromide salt) that are in thermal equilibrium to separation, then reuniting them through heat removal. The heat input and removal, achieved in a vacuum at varying pressure conditions (approximately 8 mbar and approximately 70 mbar), brings the materials into imbalance, thereby forcing them to undergo desorption or absorption. Water (refrigerant) and lithium bromide salt (absorbent) are generally used for generation of chilled water in the temperature range from 6 to 12°C. Ammonia (refrigerant) and water (absorbent) are used for low temperature chilling down to -60°C. CHCP (combined heat, cooling and power) systems – also called trigeneration systems – are the combination of cogeneration plants with absorption chillers and offer an optimal solution for generating air conditioning and/or refrigeration.

## the Jenbacher concept

Combining a cogeneration plant with an absorption refrigeration system allows utilization of seasonal excess heat for cooling. The hot water from the cooling circuit of the cogeneration plant serves as drive energy for the absorption chiller. The hot exhaust gas from the gas engine can also be used as an energy source for steam generation, which can then be utilized as an energy source for a highly efficient, double-effect steam chiller. Up to 80% of the thermal output of the cogeneration plant is thereby converted to chilled water. In this way, the year-round capacity utilization and the overall efficiency of the cogeneration plant can be increased significantly.

CHCP systems supply energy in three forms:

- Electricity
- Heat
- Chilled water

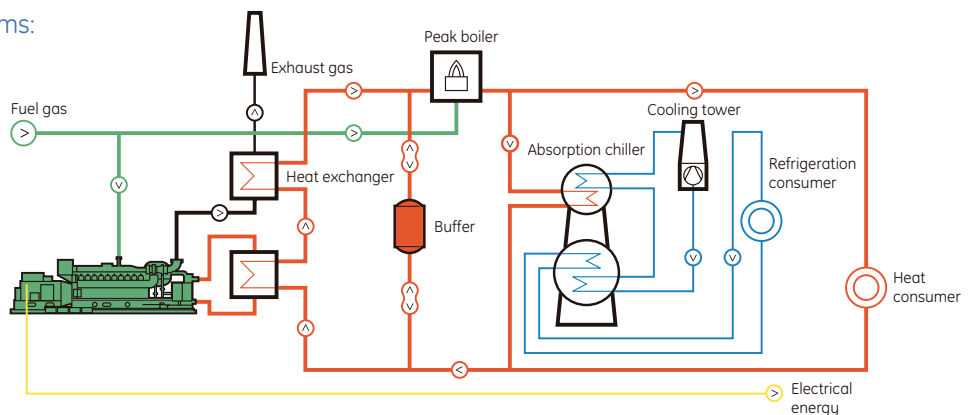

### advantages of trigeneration systems over conventional refrigeration technology

- Operated with heat, utilizing relatively inexpensive "excess energy"
- Produced electricity can be fed into the public grid or used to cover electricity requirements of the plant
- During cold seasons the heat can be utilized to cover heat requirements
- No moving parts in absorption chillers, no wear and therefore low maintenance expenses
- Noiseless operation of the absorption system
- Low operating costs and life cycle costs
- Water as refrigerant, no use of ozone-damaging substances

Absorption-type refrigeration technology offers the most established and economic solution for reduced emission, air conditioning systems.



### key figures

- Approximately 150 to 170 kW of cold output is required per 1,000 m<sup>2</sup> of office space
- The term tons of refrigeration (TR) is generally used as the unit of cold energy:  
1 TR(US) = 3.52 kWh, 1 TR(metric) = 3.86 kWh
- The term coefficient of performance (COP) is used for referring to the efficiency of an absorption chiller.  
For a hot water chiller, this lies between 0.6 and 0.8 and for a double-effect steam chiller between 1.2 and 1.3
- Cold water temperatures down to 4.5°C can be achieved with lithium bromide salt; with ammonia, temperatures down to -60°C can be achieved

### our competence

Across the world, there is a new emphasis on projects that combine climate protection and economical primary power generation. Absorption chiller technology represents an optimal solution for a year-round efficient source of cooling and heat, especially when used in conjunction with a gas engine cogeneration plant. Approximately 150 systems with Jenbacher engines in combination with absorption chillers are already in operation throughout the world. With its experience and close cooperation with absorption chiller manufacturers, the Jenbacher product team is constantly working on customized solutions in this area.



GE Energy's gas engine business is one of the world's leading manufacturers of gas-fueled reciprocating engines, packaged generator sets and cogeneration units for power generation. It is one of the only companies in the world focusing exclusively on gas engine technology.

Jenbacher engines range in power from 0.25 to 3 MW and run on either natural gas or a variety of other gases (e.g., biogas, landfill gas, coal mine gas, sewage gas, combustible industrial waste gases).

A broad range of commercial, industrial, and municipal customers use Jenbacher products for on-site generation of power, heat, and cooling. Patented combustion systems, engine controls, and monitoring enable its power generation plants to meet the strictest international emission standards, while offering high levels of efficiency, durability, and reliability.

GE Energy's Jenbacher product team has its headquarters, production facilities, and 1,000 of its more than 1,250 worldwide employees in Jenbach, Austria.



## for more information on Jenbacher products

### Austria (Headquarters)

Achenseestraße 1-3  
A-6200 Jenbach  
T +43 5244 600-0  
F +43 5244 600-527  
E [info@gejenbacher.com](mailto:info@gejenbacher.com)  
[www.gejenbacher.com](http://www.gejenbacher.com)

### Denmark

Industrivej 19  
DK-8881 Thorsø  
T +45 86966788  
F +45 86967072

### Germany

Amselstraße 28  
D-68307 Mannheim  
T +49 621 77094-0  
F +49 621 77094-70

### Hong Kong

15 Floor, The Lee Gardens  
33 Hysan Avenue Causeway Bay  
T +852 2100 6976  
F +852 2100 6630

### Italy

Via Crocioni, 46/H, Casella Postale n. 41 Aperta  
I-37012 Bussolengo (VR)  
T +39 045 6760211  
F +39 045 6766322

### Spain and Portugal

Avda. del Camino de lo Cortao, 34 - Nave 8  
E-28700 San Sebastián de los Reyes (Madrid)  
T +34 916586800  
F +34 916522616

### The Netherlands

Stationspark 750  
NL-3364 DA Sliedrecht  
T +31 184 495222  
F +31 184 415440

### United Arab Emirates

Dubai Airport Free Zone, W 1, Suite 220  
PO Box 54338, Dubai  
T +971 4 2996678  
F +971 4 2996679

### USA

15855 Jacinto Port Blvd  
Houston, TX 77015  
T +1 281 8642765  
F +1 281 8642506

